

REV.	ECN.NO.	APPD.
AO	/	/

- NOTES:
- MATERIAL:
    - Housing:thermoplastic plastics
    - terminals:Copper Alloy  
Gold plated in contact area:  
Tin plated in termination  
Nickel Plated overall
    - Shell:Steel&Copper Alloy  
Nickel Plated overall
  - ELECTRICAL CHARACTERISTICS:
    - Rating Current :1.5 Ampere
    - Rating Voltage :30 V Max
    - Contact Resistance:30 Milli ohms
    - Insulation Resistance:1000 Mega ohms Min.
  - MECHANICAL CHARACTERISTICS:
    - Connector Mating force: 35N MAX(3.57Kgf)
    - Connector Unmating force:10N min(1.02Kgf)
    - Durability:1500Cycles.
  - ENVIRONMENT CHARACTERISTICS:
    - Operating temperature:-0°C to +50°C
    - Storage temperature:-20°C to +60°C

U222-292X-XXX0X8

- 1:铜壳镀镍
- 1:吸塑盒
- 1:黑色
- 1:半金1u"
- 6:LCP

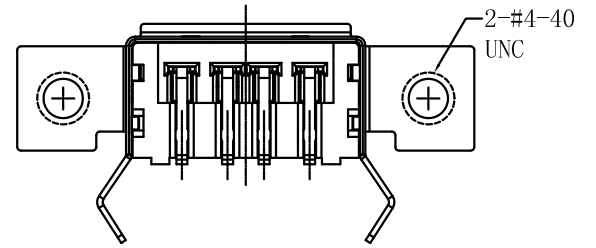
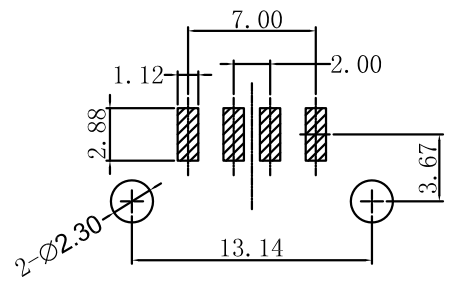
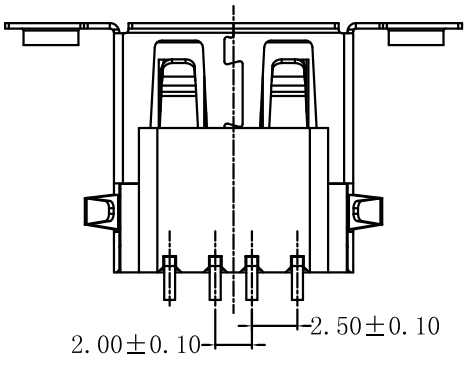
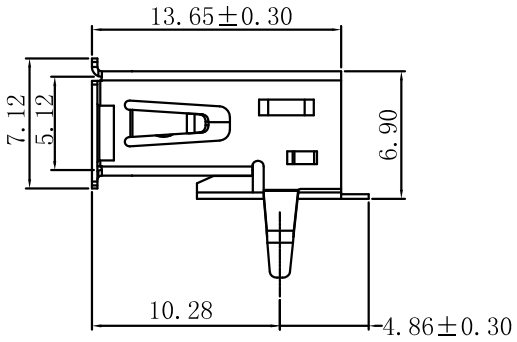
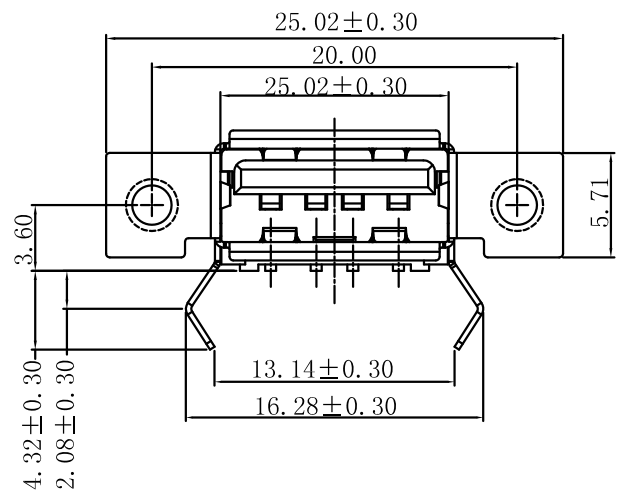
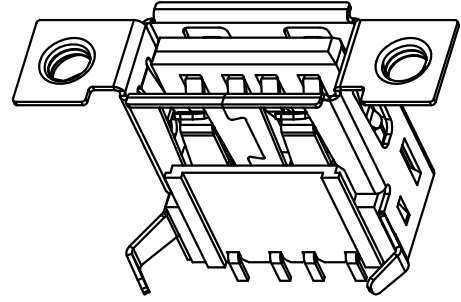
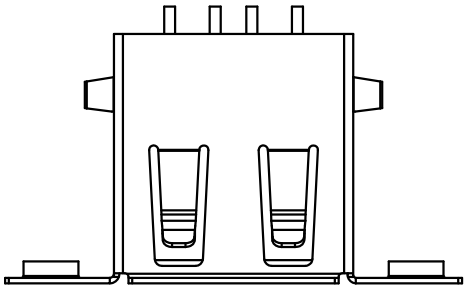

TOLERANCE UNLESS OTHERWISE SPECIFIED		<b>HLW</b> 深圳市华联威电子科技有限公司					
.XXX ±0.10		HUA LIAN WEI TECHNOLOGY ELECTRONICS CO;LTD.					
.XX ±0.20		.X' ±3'					
.X ±0.30		.XX' ±2'					
APPROVED		PART NAME:	USB AF 90度带双耳				
CHECKED		PART No:	U222-2921-161018			C	
DRAWN	weihong	PROJECTION:	UNIT:	SCALE	SHEET	REV.	
DATE	2023.03.15		mm	1:1	10F1	AO	