

9

8

7

6

5

4

3

2

1

REV.	ECN.NO.	APPD.
A	/	chenyiting

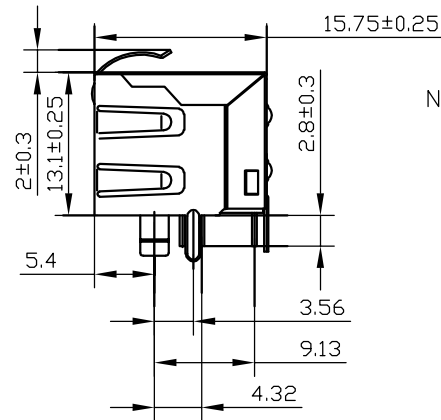
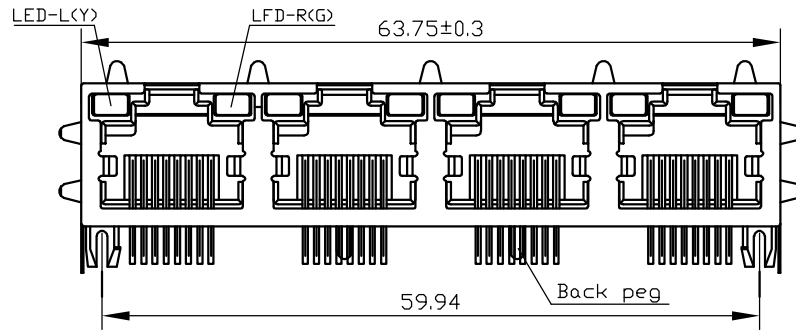

NOTES:

1.MATERIAL:

1.1 Housing:thermoplastic plastics

1.2 terminals:Copper Alloy

Gold plated in contact area:

OR Gold Plated overall

1.3 Shell:Steel&Copper Alloy

Nickel/Tin Plated overall

2.ELECTRICAL CHARACTERISTICS:

2.1 Rating Current :1.5 Ampere

2.2 Rating Voltage :125 V Max

2.3 Contact Resistance:50 Milli ohms

2.4 Insulation Resistance:500 Mega ohms Min.

3.MECHANICAL CHARACTERISTICS:

3.1 Connector Mating force: 2.27kgf MAX

3.2 Durability:750Cycles.

4.ENVIRONMENT CHARACTERISTICS:

4.1 Operating temperature:-40°C to +85°C

4.2 Storage temperature:-10°C to +40°C

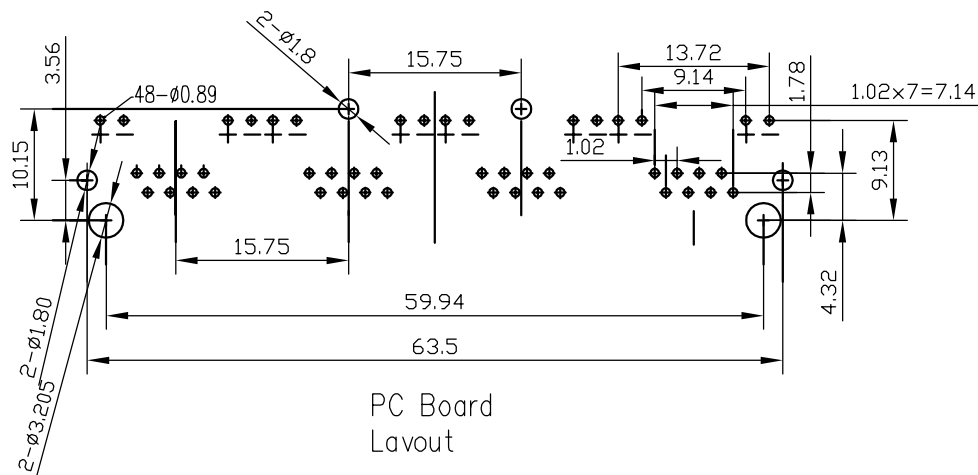
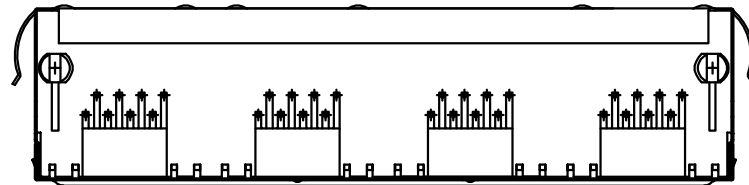
PC Board
LAYOUT

R570-15129-G31018

2:左黄右绿

G:半金G/Fu"

1:吸塑盒

1:黑色

3:PA46

TOLERANCE UNLESS OTHERWISE SPECIFIED		FLW 深圳市华联威电子科技有限公司				
.XXX ±0.10	.XX ±0.20	.X ±0.30	HUA LIAN WEI TECHNOLOGY ELECTRONICS CO;LTD.			
.X' ±3'	.XX' ±2'					
APPROVED		PART NAME:	RJ45 1X4 带弹带灯 左黄右绿LED			
CHECKED		PART No:	R570-15129-G31018	C		
DRAWN	chenyiting	PROJECTION:	UNIT:	SCALE	SHEET	REV.
DATE	2023.05.29		mm	1:1	10F1	A

9

8

7

6

5

4

3

2

1