

| | | |
|------|---------|-------|
| REV. | ECN.NO. | APPD. |
| A | / | LWQ |

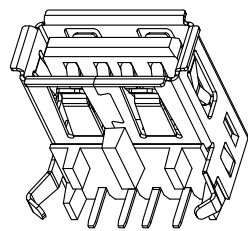

NOTES:

- 1.MATERIAL:
 - 1.1 Housing:thermoplastic plastics
 - 1.2 terminals:Copper Alloy
Gold plated in contact area:
Tin plated in termination
Nickel Plated overall
 - 1.3 Shell:Steel&Copper Alloy
Nickel Plated overall
- 2.ELECTRICAL CHARACTERISTICS:
 - 2.1 Rating Current :1.5 Ampere
 - 2.2 Rating Voltage :30 V Max
 - 2.3 Contact Resistance:30 Milli ohms
 - 2.4 Insulation Resistance:1000 Mega ohms Min.
- 3.MECHANICAL CHARACTERISTICS:
 - 3.1 Connector Mating force: 35N MAX(3.57Kgf)
 - 3.2 Connector Unmating force:10N min(1.02Kgf)
 - 3.3 Durability:1500Cycles.
- 4.ENVIRONMENT CHARACTERISTICS:
 - 4.1 Operating temperature:-0°C to +50°C
 - 4.2 Storage temperature:-20°C to +60°C

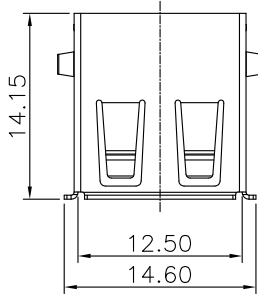
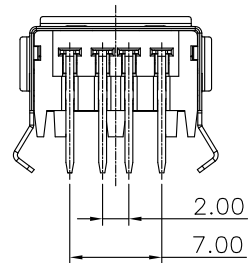
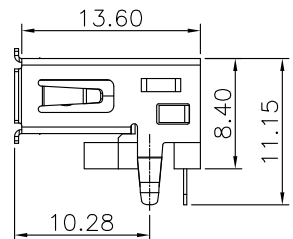
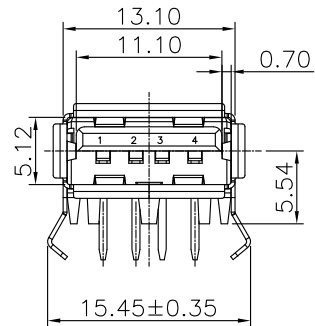

U221-1025-121111

5:Copper alloy
Ni plating

1:tray

1:Black

1: Au 1u"

2:PBT

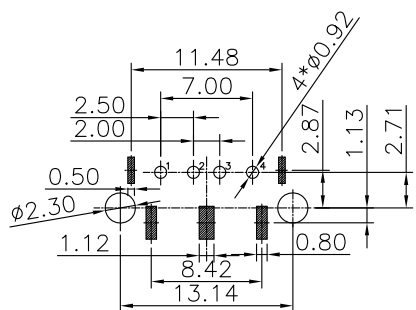

PCB LAYOUT
TOLERANCE: ±0.05
T=1.00mm

| | | | | | |
|--------------------------------------|------------|---------------------------|------------------|--|-----------|
| TOLERANCE UNLESS OTHERWISE SPECIFIED | | FLW 深圳市华联威电子科技有限公司 | | | |
| .XXX ±0.10 .XX ±0.20 .X ±0.30 | | .X' ±3' .XX' ±2' | | HUA LIAN WEI TECHNOLOGY ELECTRONICS CO.;LTD. | |
| APPROVED | | PART NAME: | USB AF 90度加高型无后盖 | | |
| CHECKED | | PART No: | U221-1025-121111 | C | |
| DRAWN | Luwenqi | PROJECTION: | UNIT: | SCALE | SHEET |
| DATE | 2015.02.05 | | mm | 1:1 | 10F1 |
| | | | | | REV. A |