

REV.	ECN.NO.	APPD.
A	/	/

NOTES:

- 1.MATERIAL:
 - 1.1 Housing:thermoplastic plastics
 - 1.2 terminals:Copper Alloy
Gold plated in contact area:
Tin plated in termination
Nickel Plated overall
 - 1.3 Shell:Steel&Copper Alloy
Nickel Plated overall
- 2.ELECTRICAL CHARACTERISTICS:
 - 2.1 Rating Current :1.5 Ampere
 - 2.2 Rating Voltage :30 V Max
 - 2.3 Contact Resistance:30 Milli ohms
 - 2.4 Insulation Resistance:1000 Mega ohms Min.
- 3.MECHANICAL CHARACTERISTICS:
 - 3.1 Connector Mating force: 35N MAX(3.57Kgf)
 - 3.2 Connector Unmating force:10N min(1.02Kgf)
 - 3.3 Durability:1500Cycles.
- 4.ENVIRONMENT CHARACTERISTICS:
 - 4.1 Operating temperature:-0°C to +50°C
 - 4.2 Storage temperature:-20°C to +60°C

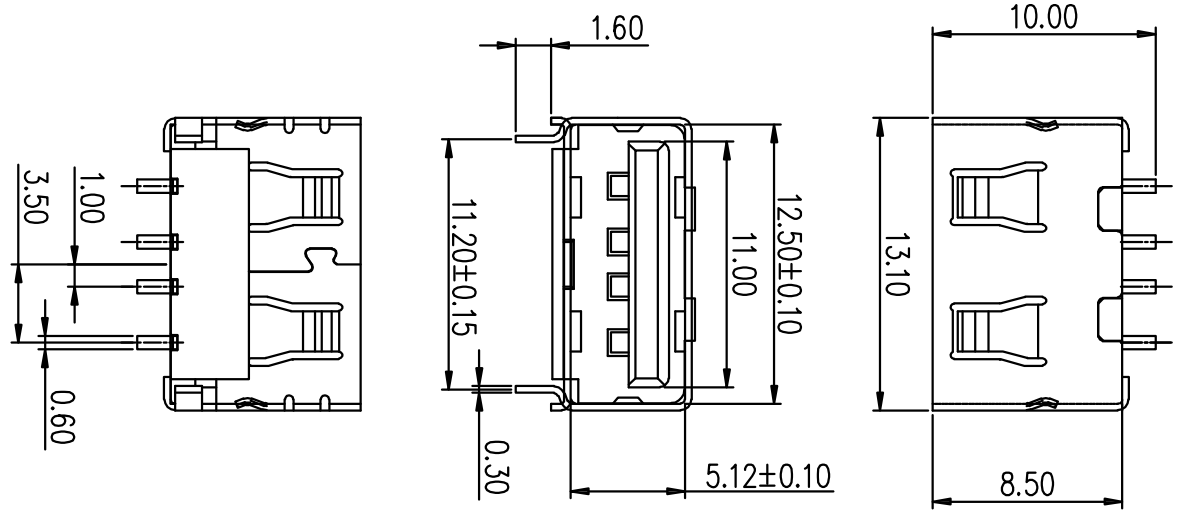

U221-3011-G61018

- 1:铁壳镀镍
- G:半金G/Fu"
- 1:吸塑盒
- 1:黑色
- 6:LCP

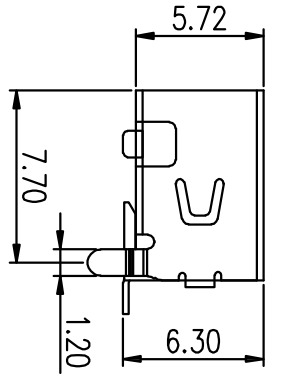
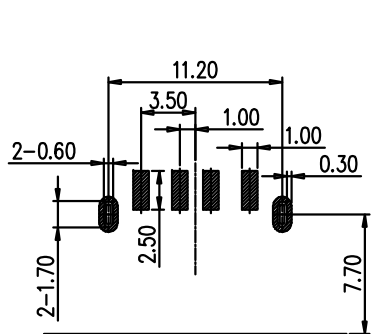

TOLERANCE UNLESS OTHERWISE SPECIFIED		FLW 深圳市华联威电子科技有限公司				
		HUA LIAN WEI TECHNOLOGY ELECTRONICS CO;LTD.				
.XXX ±0.10	.XX ±0.20	.X ±0.30	.X' ±3'	.XX' ±2'	PART NAME: USB AF 短体无卷边8.5	
APPROVED		CHECKED	chenyiting	PART No:	U221-3011-G61018	C
DRAWN	chenyiting	PROJECTION:		UNIT:	mm	SCALE: 1:1
DATE	2023.05.20			SHEET	10F1	REV. A