

REV.	ECN.NO.	APPD.
A	XXXXXXXXXX	yangguifeng

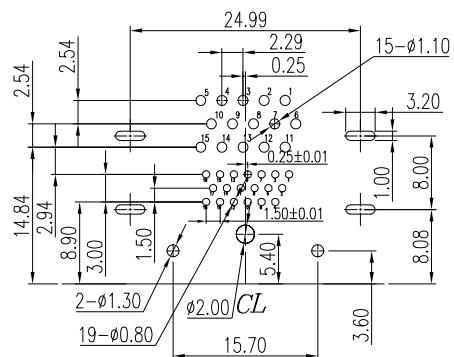
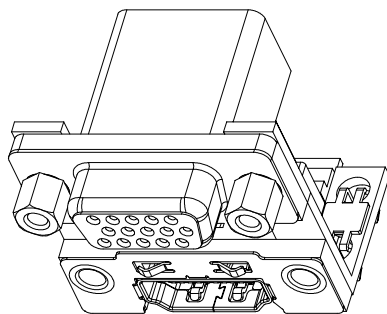
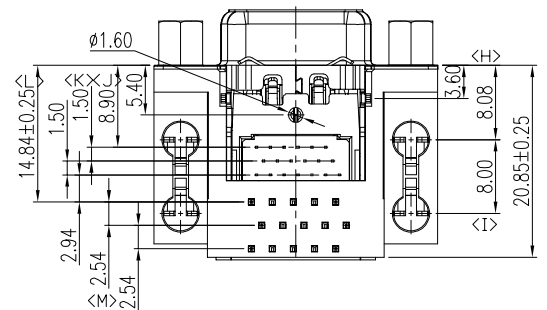
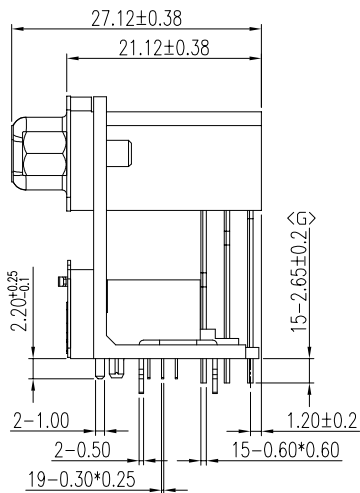
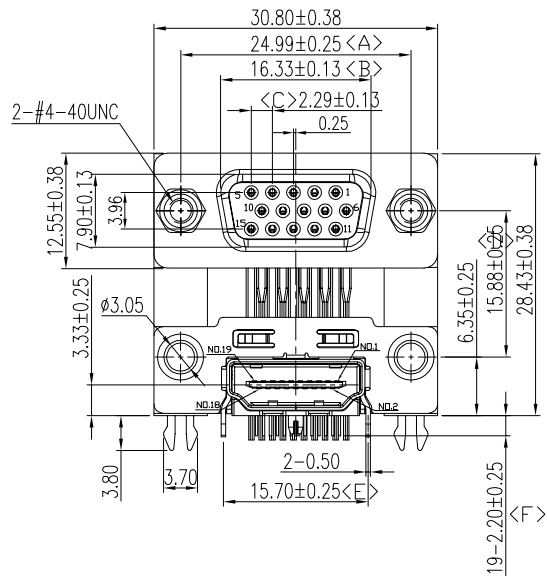

RECOMMENDED P.C.B LAYOUT
INSPECTION DIMENSION:(A)~(M)

SPECIFICATIONS

- 1.1 Voltage: 250 VAC(RMS) Max.
- 1.2 Current Rating: 3 Ampere per Contact
- 1.3 Contact Resistance: 25 Milliohms Max.
- 1.4 Insulation Resistance: 5000 Megohms Min.
- 1.5 Dielectric Withstanding Voltage: 1000 VAC(RMS)
- 1.6 Total Mating Force: 6.0 Kgf Max.
- 1.7 Total Unmating Force: 1.2 Kgf Min.
- 1.8 Operating Temperature: -55°C to +85°C

- 2.1 Voltage: 40 VAC(RMS) Max.
- 2.2 Current Rating: 0.5 Ampere per Contact
- 2.3 Contact Resistance: 30 Milliohms Max.
- 2.4 Insulation Resistance: 100 Megohms Min.
- 2.5 Dielectric Withstanding Voltage: 500V DC(RMS)
- 2.6 Total Mating Force: 4.5 Kgf Max.
- 2.7 Total Unmating Force: 1.0 Kgf Min.
- 2.8 Operating Temperature: -55°C to +85°C

NOTES

1. MATERIAL:
 - Housing(VGA):PBT, UL 94V-0, Color:Blue.
 - Housing(HDMI):LCP, UL 94V-0, Color:Black.
 - Connecting Pedestal:PBT, UL 94V-0, Color:Black.
 - Terminal:Copper Alloy.
 - Shell(VGA):SPCC.
 - Shell(HDMI):SUS.
 - Boardlock:Copper Alloy.
 - Bracket:Zinc Alloy.
 - Gasket:Stainless Steel.
 - Screw:Steel.
2. FINISH:
 - Terminal:Gold Plated Over Nickel at Contact Area.
 - Tin Plated Over Nickel at Solder Ared.
 - Shell:Nickel Plated.
 - Boardlock:Tin Plated.
 - Bracket:Nickel Plated.
 - Screw:Nickel Plated.
3. This Product is LEAD-FREE & RoHS Compliance Product.

DS813-0131-XXX8

G: 半金G/Fu"

7: 蓝色+黑色

A: PBT+LCP

TOLERANCE UNLESS OTHERWISE SPECIFIED	
.XXX ±0.10	.X' ±3'
.XX ±0.20	.XX' ±2'
.X ±0.30	

FLW 深圳市华联威电子科技有限公司
HUA LIAN WEI TECHNOLOGY ELECTRONICS CO;LTD.

APPROVED		PART NAME:	HDR15母+HDR15母H15. 88铆锁卧式			
CHECKED		PART No:	DS813-0131-GA78	C		
DRAWN	yangguifeng	PROJECTION:	UNIT:	SCALE:	SHEET:	REV.
DATE	2021.12.01		mm	1:1	1 OF 1	A