

REV.	ECN.NO.	APPD.
A	/	/

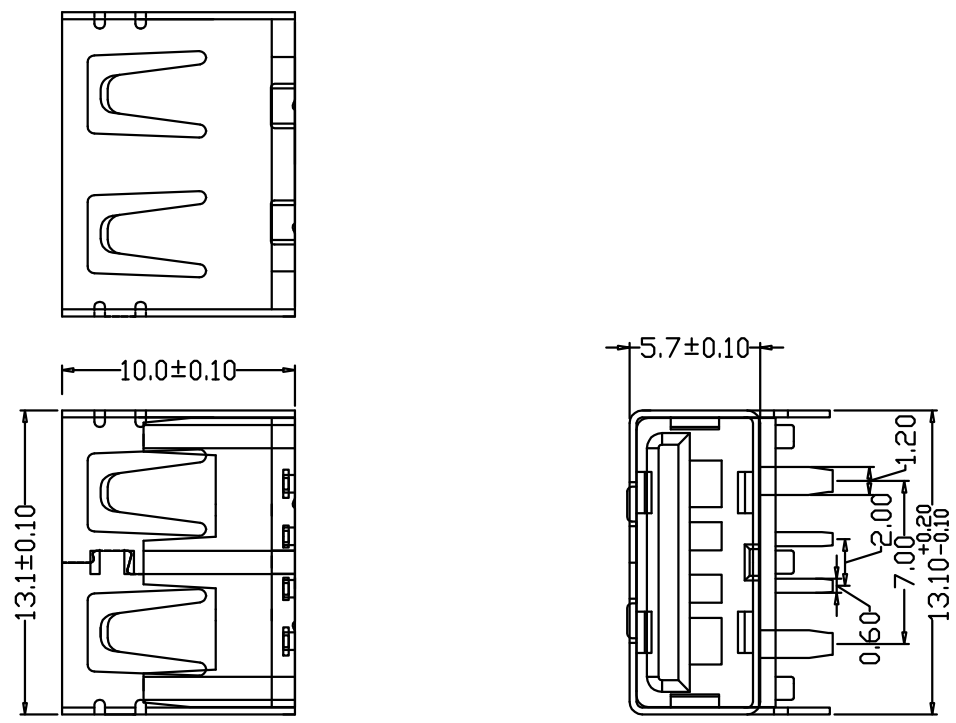

- NOTES:
- MATERIAL:
 - Housing: thermoplastic plastics
 - terminals: Copper Alloy
Gold plated in contact area:
Tin plated in termination
Nickel Plated overall
 - Shell: Steel & Copper Alloy
Nickel Plated overall
 - ELECTRICAL CHARACTERISTICS:
 - Rating Current : 1.5 Ampere
 - Rating Voltage : 30 V Max
 - Contact Resistance: 30 Milli ohms
 - Insulation Resistance: 1000 Mega ohms Min.
 - MECHANICAL CHARACTERISTICS:
 - Connector Mating force: 35N MAX(3.57Kgf)
 - Connector Unmating force: 10N min(1.02Kgf)
 - Durability: 1500 Cycles.
 - ENVIRONMENT CHARACTERISTICS:
 - Operating temperature: -0°C to $+50^{\circ}\text{C}$
 - Storage temperature: -20°C to $+60^{\circ}\text{C}$

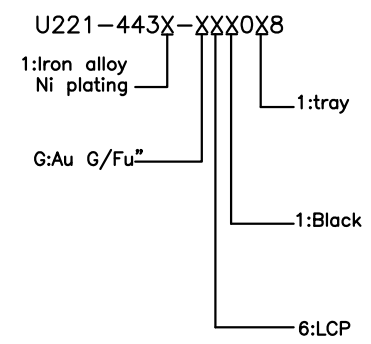

TOLERANCE UNLESS OTHERWISE SPECIFIED		FLW 深圳市华联威电子科技有限公司 HUA LIAN WEI TECHNOLOGY ELECTRONICS CO;LTD.			
.XXX ± 0.10	.XX ± 0.20	.X* $\pm 3^{\circ}$			
.X ± 0.30	.XX* $\pm 2^{\circ}$				
APPROVED		PART NAME:	USB AF 短体10.0 90度两脚无卷边		
CHECKED		PART No:	U221-4431-G61018	C	
DRAWN	weihong	PROJECTION:	UNIT:	SCALE	SHEET
DATE	2021.11.06		mm	1:1	10F1
					REV. A