

REV.	ECN.NO.	APPD.
A	/	weihong

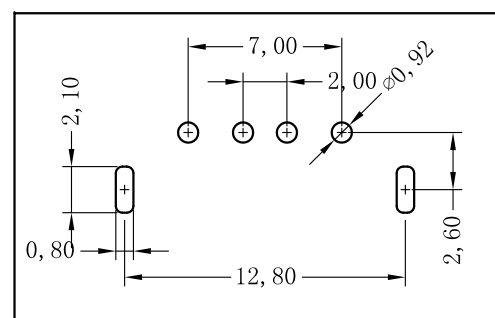
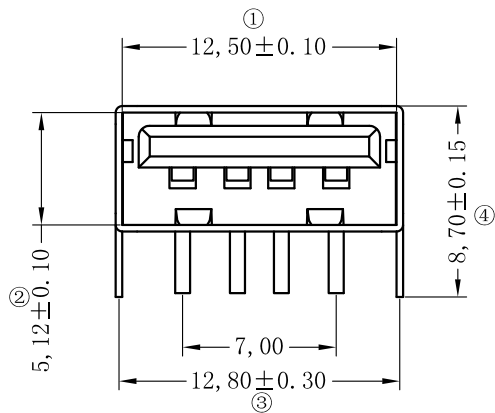
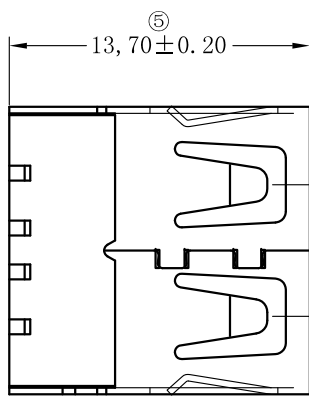
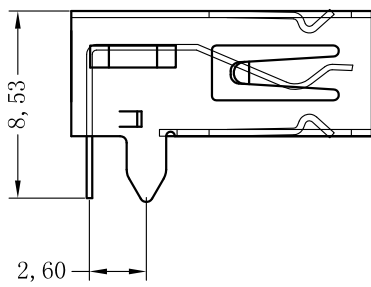
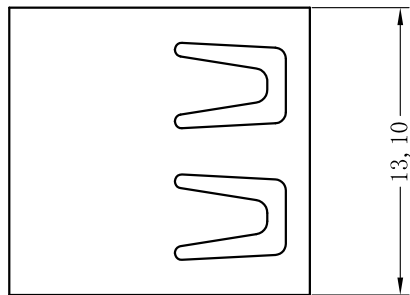

- NOTES:
- MATERIAL:
 - Housing:thermoplastic plastics
 - terminals:Copper Alloy
Gold plated in contact area:
Tin plated in termination
Nickel Plated overall
 - Shell:Steel&Copper Alloy
Nickel Plated overall
 - ELECTRICAL CHARACTERISTICS:
 - Rating Current :1.5 Ampere
 - Rating Voltage :30 V Max
 - Contact Resistance:30 Milli ohms
 - Insulation Resistance:1000 Mega ohms Min.
 - MECHANICAL CHARACTERISTICS:
 - Connector Mating force: 35N MAX(3.57KgF)
 - Connector Unmating force:10N min(1.02KgF)
 - Durability:1500Cycles.
 - ENVIRONMENT CHARACTERISTICS:
 - Operating temperature:-0°C to +50°C
 - Storage temperature:-20°C to +60°C

U221-A11X-XXX0X7

1:Iron alloy
Ni plating

G:半金G/Fu"

1:吸塑盘
2:白色
2:PBT

TOLERANCE UNLESS OTHERWISE SPECIFIED		深圳市华联威电子科技有限公司 HUA LIAN WEI TECHNOLOGY ELECTRONICS CO., LTD.			
.XXX ±0.10	.XX ±0.20				
APPROVED		PART NAME:	USB AF 90度直脚无卷边		
CHECKED		PART No:	U221-A111-G22017		C
DRAWN	weihong	PROJECTION:	UNIT:	SCALE	SHEET
DATE	2022.07.04		mm	1:1	10F1
					REV. A