

| | | |
|------|-------------|-------------|
| REV. | ECN.NO. | APPD. |
| A | EXXXXXXXXXX | yangguifeng |

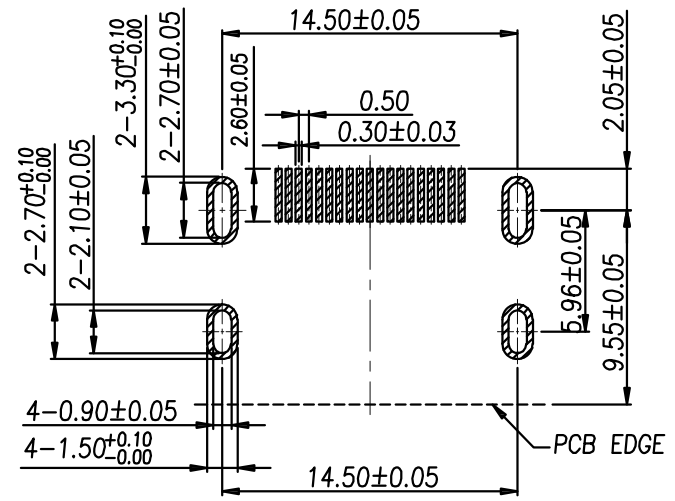
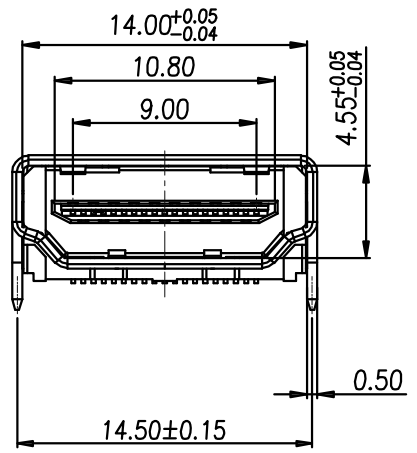
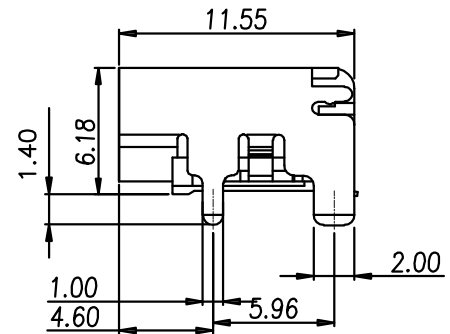
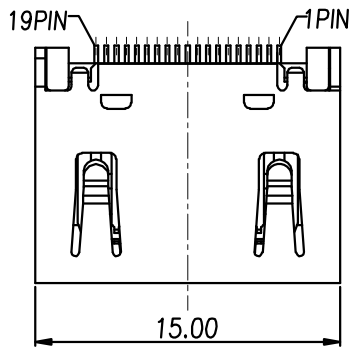

RECOMMENDED PCB LAYOUT (T:1.60mm)
TOLERANCE UNSPECIFIED ±0.10mm

- NOTES:
- MATERIAL:
 - Housing:thermoplastic plastics
 - terminals:Copper Alloy
Gold plated in contact area:
Tin plated in termination
Nickel Plated overall
 - Shell:Steel&Copper Alloy
Nickel/Au Plated overall
 - ELECTRICAL CHARACTERISTICS:
 - Rating Current :0.5 Ampere
 - Rating Voltage :40 V Max
 - Contact Resistance:30 Milli ohms
 - Insulation Resistance:100 Mega ohms Min.
 - MECHANICAL CHARACTERISTICS:
 - Connector Mating force: 4.5kg MAX
 - Connector Unmating force:1.0Kg min
 - Durability:10000Cycles.
 - ENVIRONMENT CHARACTERISTICS:
 - Operating temperature:-20°C to +85°C
 - Storage temperature:-20°C to +65°C

HD22-2511-161218

1:铁壳镀镍
 1:1u" Au
 6:LCP

1:载带
 1:黑色

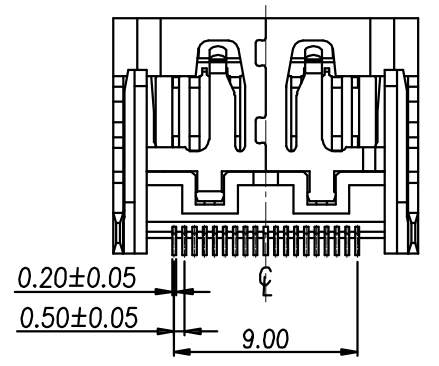

| | |
|--------------------------------------|----------|
| TOLERANCE UNLESS OTHERWISE SPECIFIED | |
| .XXX ±0.10 | .X' ±3' |
| .XX ±0.20 | .XX' ±2' |
| .X ±0.30 | |

FLW 深圳市华联威电子科技有限公司
HUA LIAN WEI TECHNOLOGY ELECTRONICS CO.,LTD.

| | | | | | | |
|----------|------------|-------------|--------------------------|-------|--------|------|
| APPROVED | | PART NAME: | HDMI 19P/F SMT 短体9.5 四脚插 | | | |
| CHECKED | | PART No: | HD22-2511-161218 | C | | |
| DRAWN | chenyiting | PROJECTION: | UNIT: | SCALE | SHEET | REV. |
| DATE | 2022.12.29 | | mm | 1:1 | 1 OF 1 | A |