

REV.	ECN.NO.	APPD.
A	/	LXQ

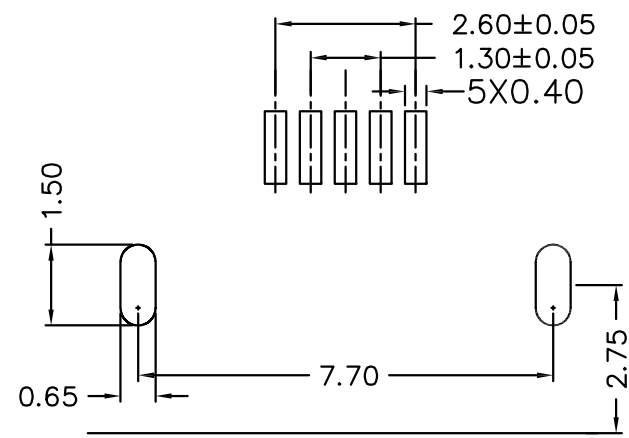

PCB LAYOUT

- NOTES:
- MATERIAL:
 - Housing: thermoplastic plastics,
 - terminals: Copper Alloy
Gold plated overall
 - Shell: Steel & Copper Alloy
Nickel/Tin Plated overall
 - ELECTRICAL CHARACTERISTICS:
 - Rating Current : 1.5 Ampere
 - Rating Voltage : 30 V Max
 - Contact Resistance: 50 Milli ohms
 - Insulation Resistance: 100 Mega ohms Min.
 - MECHANICAL CHARACTERISTICS:
 - Connector Mating force: 35N MAX
 - Connector Unmating force: 7N min
 - ENVIRONMENT CHARACTERISTICS:
 - Operating temperature: -0°C to +50°C
 - Storage temperature: -20°C to +60°C

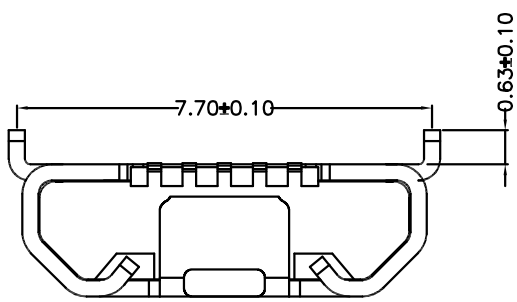
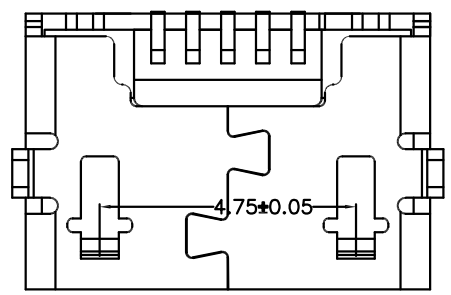
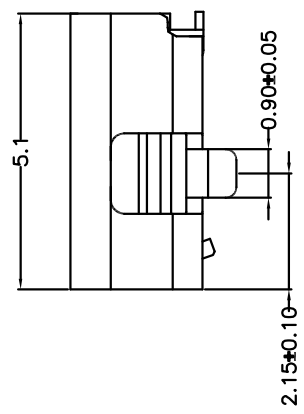
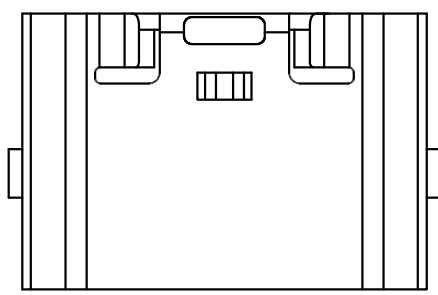

- U444-0816-G61018
- 6: 铜壳镀雾锡
 - G: 半金G/Fu
 - 6: LCP
 - 1: 吸塑盘
 - 1: 黑色

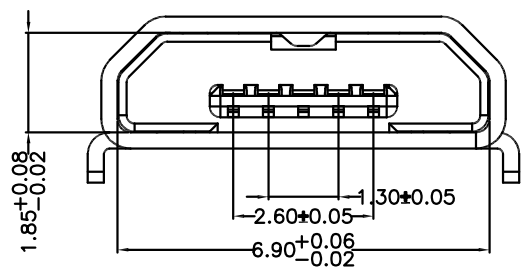

TOLERANCE UNLESS OTHERWISE SPECIFIED		FLW 深圳市华联威电子科技有限公司					
.XXX ±0.10		HUA LIAN WEI TECHNOLOGY ELECTRONICS CO;LTD.					
.XX ±0.20		.X' ±3'		PART NAME:		MICRO 5P B 反向两脚无卷边	
.X ±0.30		.XX' ±2'		CHECKED		PART No: U444-0816-G61018 C	
APPROVED		Shen		PROJECTION:		UNIT: SCALE: SHEET: REV.	
DATE: 2021.08.30		mm		7:1		1 OF 1 A	