

RoHS

REV.	ECN.NO.	APPD.
A	XXXXXXXXXX	Hexing

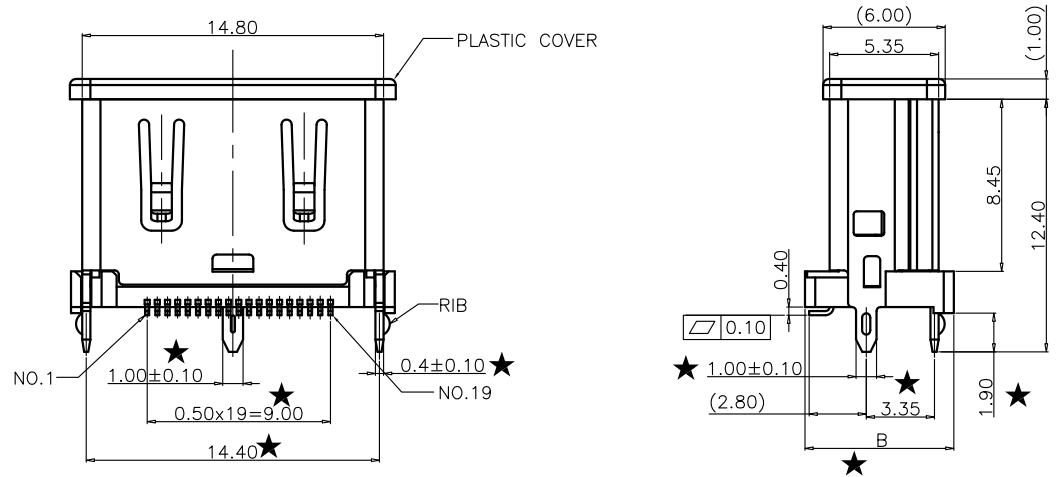

- NOTES:
- MATERIAL:
 - Housing:thermoplastic plastics
 - terminals:Copper Alloy
Gold plated in contact area:
Tin plated in termination
Nickel Plated overall
 - Shell:Steel&Copper Alloy
Nickel/Au Plated overall
 - ELECTRICAL CHARACTERISTICS:
 - Rating Current :0.5 Ampere
 - Rating Voltage :40 V Max
 - Contact Resistance:30 Milli ohms
 - Insulation Resistance:100 Mega ohms Min.
 - MECHANICAL CHARACTERISTICS:
 - Connector Mating force: 4.5kg MAX
 - Connector Unmating force:1.0Kg min
 - Durability:10000Cycles.
 - ENVIRONMENT CHARACTERISTICS:
 - Operating temperature:-20℃ to +85℃
 - Storage temperature:-20℃ to +65℃

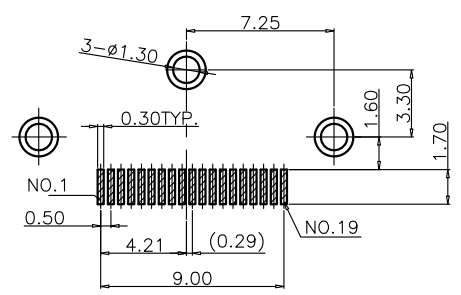
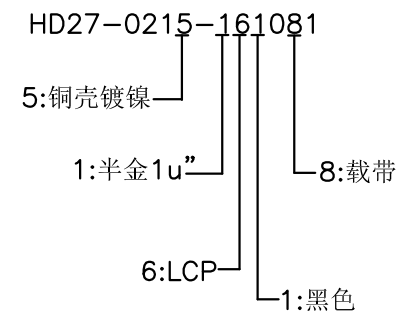
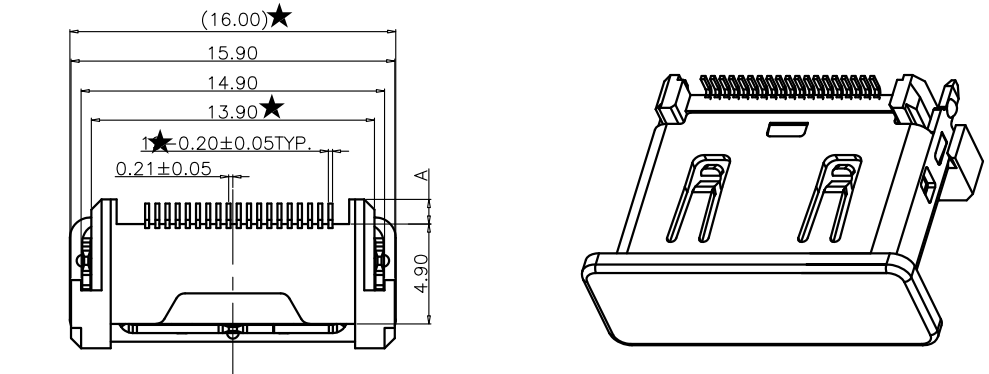

RECOMMENDED PCB LAYOUT THICKNESS = 1.6 mm
TOLERANCE:±0.05

TOLERANCE UNLESS OTHERWISE SPECIFIED		FLW 深圳市华联威电子科技有限公司			
.XXX ±0.10 .XX ±0.20 .X ±0.30		HUA LIAN WEI TECHNOLOGY ELECTRONICS CO;LTD.			
APPROVED		PART NAME:	HDMI 19P/F 180度SMT 铜壳三插脚有凸点,带防尘塞		
CHECKED		PART No:	HD27-0215-161081	C	
DRAWN	pengchaoyong	PROJECTION:	UNIT:	SCALE	SHEET
DATE	2019.01.03		mm	1:1	10F1
					REV. A