

| | | |
|------|---------|-------|
| REV. | ECN.NO. | APPD. |
| A | / | / |

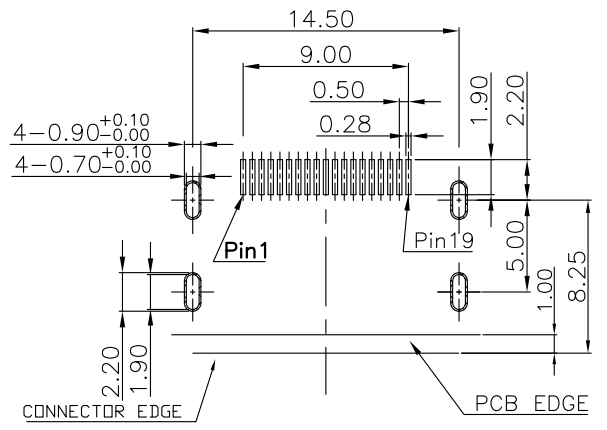

RECOMMENDED PCB LAYOUT (TOP VIEW)
TOLERANCE: ±0.05mm

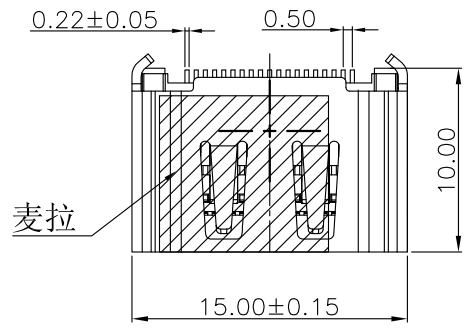
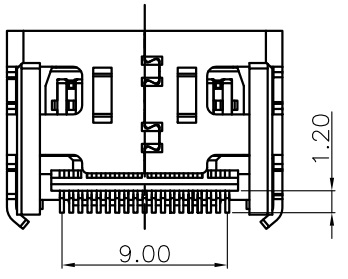
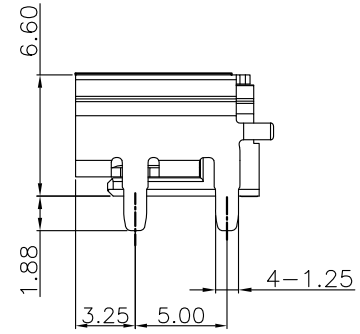
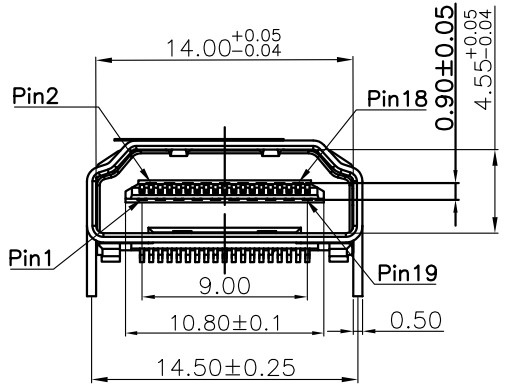

- NOTES:
- MATERIAL:
 - Housing:thermoplastic plastics
 - terminals:Copper Alloy
Gold plated in contact area:
Tin plated in termination
Nickel Plated overall
 - Shell:Steel&Copper Alloy
Nickel/Au Plated overall
 - ELECTRICAL CHARACTERISTICS:
 - Rating Current :0.5 Ampere
 - Rating Voltage :40 V Max
 - Contact Resistance:30 Milli ohms
 - Insulation Resistance:100 Mega ohms Min.
 - MECHANICAL CHARACTERISTICS:
 - Connector Mating force: 4.5kg MAX
 - Connector Unmating force:1.0Kg min
 - Durability:10000Cycles.
 - ENVIRONMENT CHARACTERISTICS:
 - Operating temperature:-20℃ to +85℃
 - Storage temperature:-20℃ to +65℃

HD22-1425-G61018

5:铜壳镀镍
G:半金G/Fu
1:吸塑盒
1:黑色
6:LCP

| | | | |
|----|-----------|-----|---|
| D | MYLAR | 1 | PI FILM BROWN |
| C | SHELL | 1 | C2680R-H Ni 50u" T=0.5mm PLATING ALL OVER |
| B | TERMINAL | 19 | C2680R-H SEE PART NO. |
| A | HOUSING | 1 | LCP E130i UL94V-0 BLACK |
| NO | PART NAME | QTY | MATERIAL PLATING & COLOR |

TOLERANCE UNLESS OTHERWISE SPECIFIED

| | |
|------------|----------|
| .XXX ±0.10 | .X' ±3' |
| .XX ±0.20 | .XX' ±2' |
| .X ±0.30 | |

FLW 深圳市华联威电子科技有限公司
HUA LIAN WEI TECHNOLOGY ELECTRONICS CO;LTD.

| | | | | | | |
|----------|-----------|-------------|------------------|-------|-------|------|
| APPROVED | | PART NAME: | HDMI 反向SMT式铜壳 | | | |
| CHECKED | | PART No: | HD22-1425-G61018 | | C | |
| DRAWN | weihong | PROJECTION: | UNIT: | SCALE | SHEET | REV. |
| DATE | 2021.7.23 | | mm | 1:1 | 10F1 | A |