

REV.	ECN.NO.	APPD.
AO	/	/

NOTES:

- MATERIAL:
 - Housing:thermoplastic plastics
 - terminals:Copper Alloy
Gold plated in contact area:
Tin plated in termination
Nickel Plated overall
 - Shell:Steel&Copper Alloy
Nickel/Au Plated overall
- characteristics:
 - Rating Voltage : 30V AC.
 - Rating Current:
5A for Vbus PIN;1.25A for Vconn PIN
 - Contact Resistance:40 mΩ MAX.
 - Insulation Resistance:100 MΩ MIN.
 - Withstanding Voltage:AC 100V
 - Mating force: 5~20N MAX
 - Extraction force:8~20N Min
 - Life test:10000Cycles MIN.
 - Temperature Range: -30℃~+80℃.
 The product must be compliance ROHS

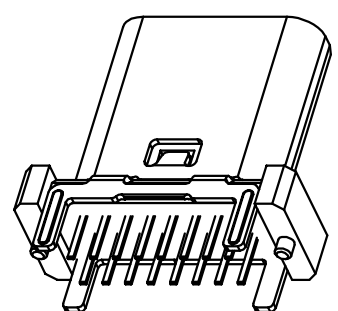
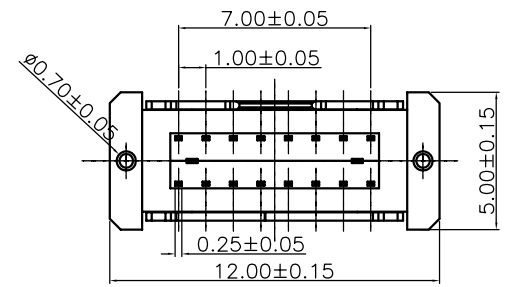
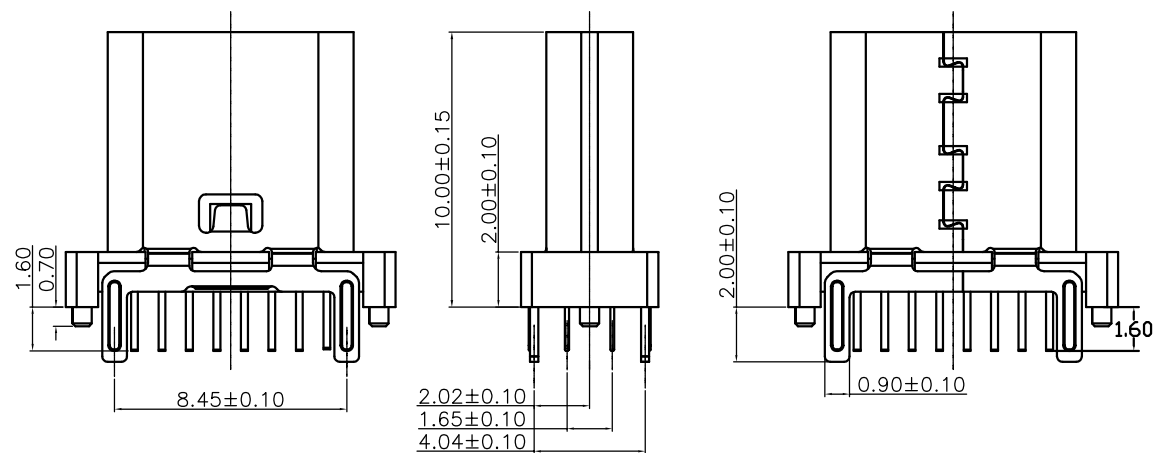
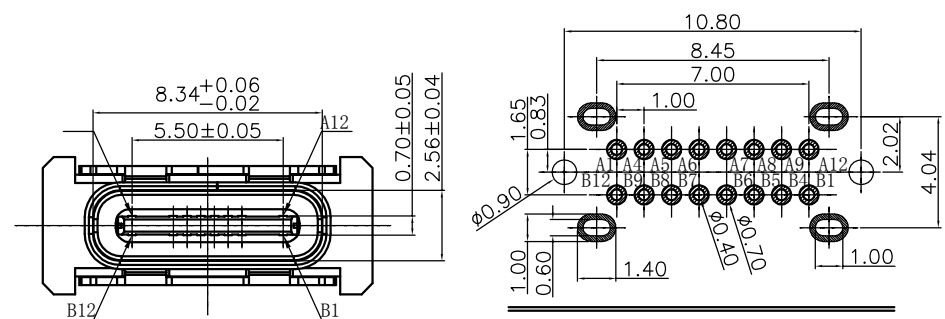

U571-051B-G61038

B: 不锈钢镀镍
G: 半金G/Fu”
3: 载带
1: 黑色
6: LCP

A1	A2	A3	A4	A5	A6	A7	A8	A9	A10	A11	A12
GND	/	/	VBUS	CC1	D+	D-	SBU1	VBUS	/	/	GND
GND	/	/	VBUS	SBU2	D-	D+	CC2	VBUS	/	/	GND
B12	B11	B10	B9	B8	B7	B6	B5	B4	B3	B2	B1

TOLERANCE UNLESS OTHERWISE SPECIFIED		深圳市华联威电子科技有限公司				
.XXX ±0.10 .XX ±0.20 .X ±0.30		.X* ±3* .XX* ±2*		HUA LIAN WEI TECHNOLOGY ELECTRONICS CO;LTD.		
APPROVED		PART NAME:	TYPE C 16P/F 直插10.0			
CHECKED		PART No:	U571-051B-G61038			C
DRAWN	weihong	PROJECTION:	UNIT:	SCALE	SHEET	REV.
DATE	2021.07.29		mm	1:1	10F1	A0