

REV.	ECN.NO.	APPD.
A0	/	/

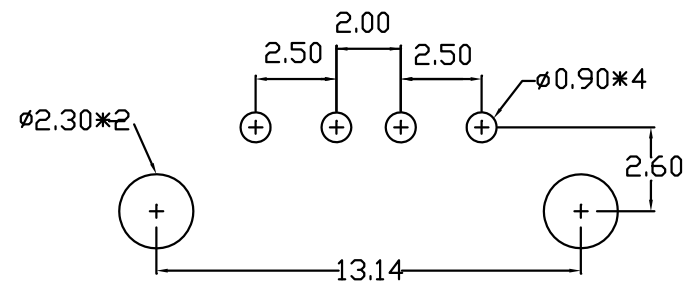
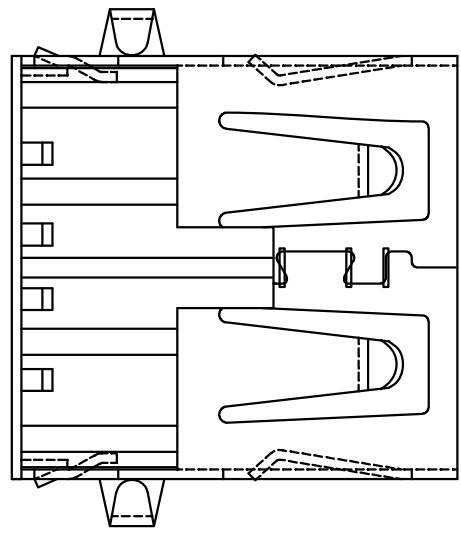
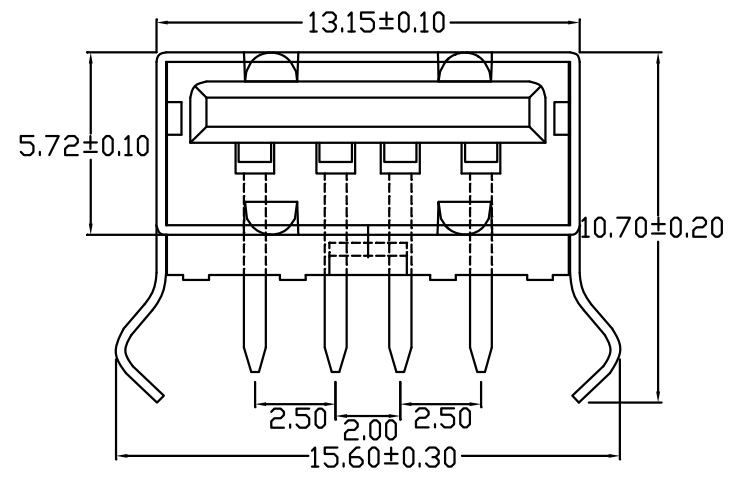
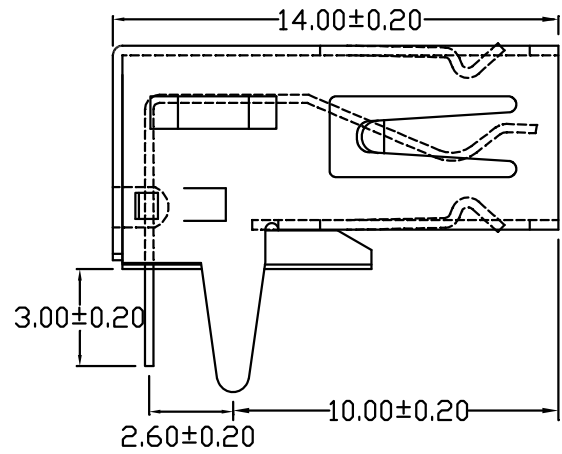

- NOTES:
- MATERIAL:
    - Housing:thermoplastic plastics
    - terminals:Copper Alloy  
Gold plated in contact area:  
Tin plated in termination  
Nickel Plated overall
    - Shell:Steel&Copper Alloy  
Nickel Plated overall
  - ELECTRICAL CHARACTERISTICS:
    - Rating Current :1.5 Ampere
    - Rating Voltage :30 V Max
    - Contact Resistance:30 Milli ohms
    - Insulation Resistance:1000 Mega ohms Min.
  - MECHANICAL CHARACTERISTICS:
    - Connector Mating force: 35N MAX(3.57Kgf)
    - Connector Unmating force:10N min(1.02Kgf)
    - Durability:1500Cycles.
  - ENVIRONMENT CHARACTERISTICS:
    - Operating temperature:-0°C to +50°C
    - Storage temperature:-20°C to +60°C

U221-962X-XXX0X7

1: 铁壳镀镍  
1: 吸塑盒  
G: 半金G/Fu  
2: 白色  
2: PBT

TOLERANCE UNLESS OTHERWISE SPECIFIED	
.XXX ±0.10	.X' ±3'
.XX ±0.20	.XX' ±2'
.X ±0.30	

**FLW** 深圳市华联威电子科技有限公司  
HUA LIAN WEI TECHNOLOGY ELECTRONICS CO;LTD.

APPROVED		PART NAME:	USB AF弯脚有盖无卷边			
CHECKED		PART No:	U221-9621-G22017			C
DRAWN	chenyiting	PROJECTION:	UNIT:	SCALE	SHEET	REV.
DATE	2023.05.30		mm	1:1	10F1	A0