

REV.	ECN.NO.	APPD.
A	EXXXXXXXXXX	chenyiting

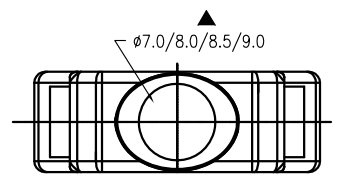
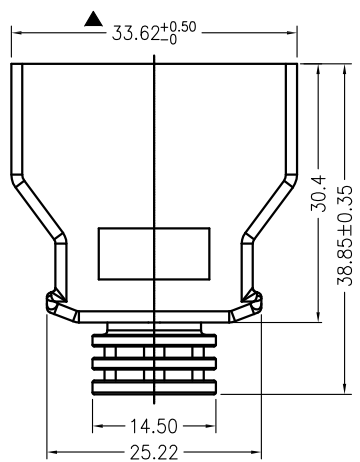
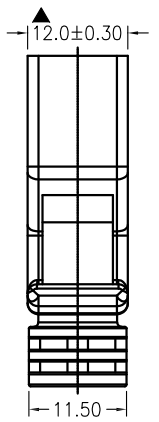
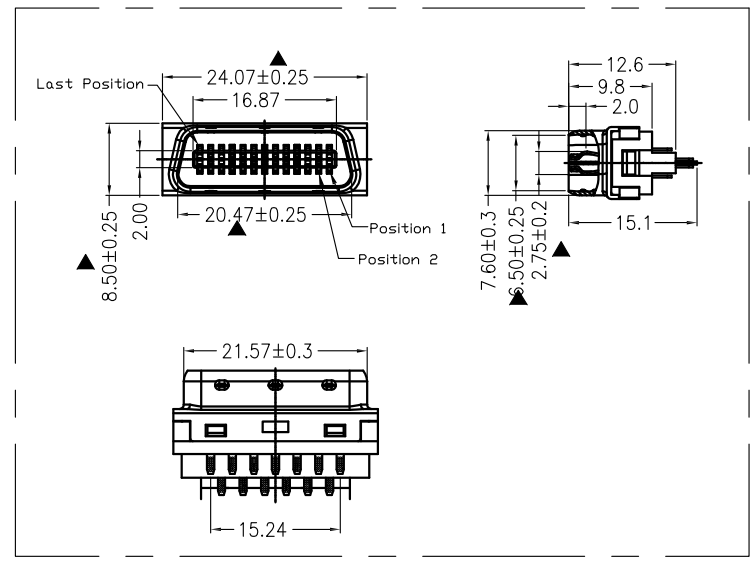
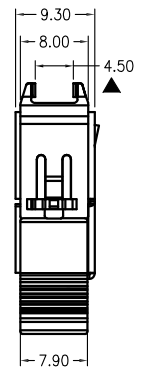
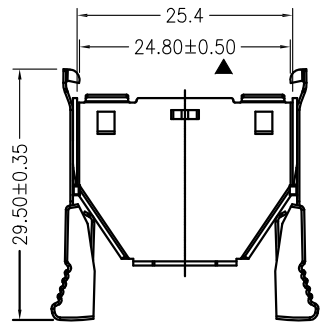
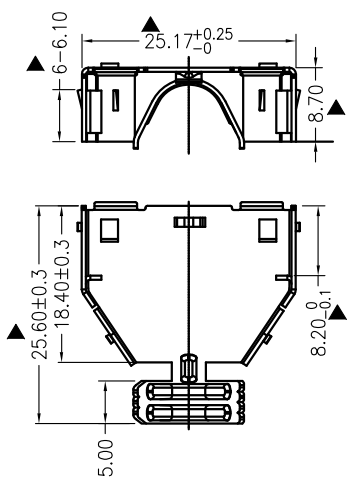

1.SPECIFICATION

- 2.1 Current Rate:5 Amps
- 2.2 Insulator Resistance:1000MΩ Min.
- 2.3 Dielectric Strength:500V AC PER MIN
- 2.4 Operation Temperature:-55℃~+105℃
- 2.5 Contact Resistance:30mΩ Max

DS812-6011-G217
 1: 铁壳镀镍
 G: 半金G/Fu
 1: 黑色
 2: PBT

TOLERANCE UNLESS OTHERWISE SPECIFIED		FLW 深圳市华联威电子科技有限公司				
		HUA LIAN WEI TECHNOLOGY ELECTRONICS CO;LTD.				
.XXX ±0.10	.X' ±3'	PART NAME:		D-SUB 焊线公座26PIN带护套		
.XX ±0.20	.XX' ±2'	CHECKED		PART No:		C
.X ±0.30	.XX' ±2'	DRAWN chenyiting		PROJECTION:		REV.
DATE 2023.04.06		mm		UNIT:	SCALE 1:1	SHEET 1 OF 1