

1. 将全检后的产品放入载带内，前空10PCS空格，后空10PCS空格，中间放250PCS产品，每箱放10盘，每箱装2500PCS
2. 将载带盘放入350*350*335的纸箱中，然后用透明胶纸封箱，箱胶带采用“工字型”封箱。
2. 依据客户要求在外箱产品标签处贴上相应的标签。

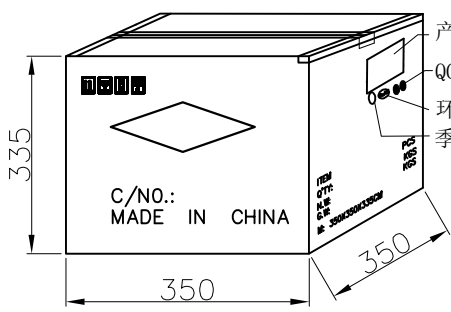
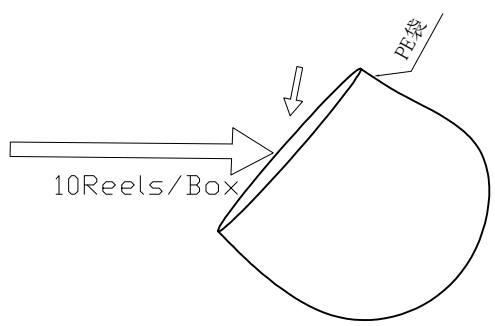
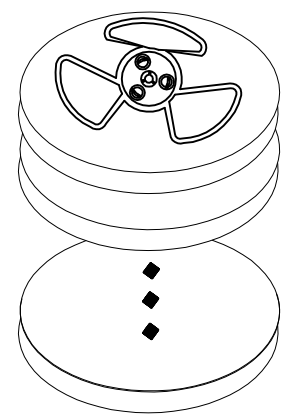
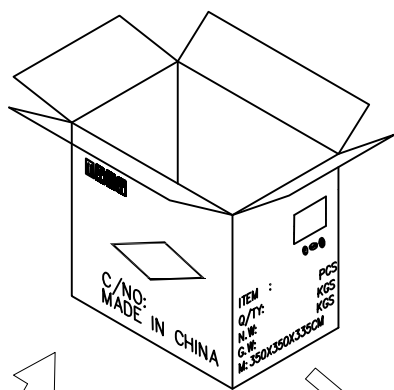

- 产品标签 (业务提供)
- QC印章, 加盖于标签的右下方
- 环保标签
- 季度标签 (可向客户购买)

TOLERANCE UNLESS OTHERWISE SPECIFIED
.XX ±0.15
.X ±0.30
X. ±0.50
.X' ±3"

产品名称	HDMI 19P/F 单耳无后盖	
PART NAME:		
料号	HD21-0915-G61018	P
图号	B-1104	
HLW 深圳市华联威电子科技有限公司 HUA LIAN WEI TECHNOLOGY ELECTRONICSCO;LTD.		

REV:	DESCRIPTION	REV BY	APPROVED	DATE	MATL:	SEE SPECIFICATION	APPROVED
A0	新版发行	A1	weihong	2021. 04. 07	mm	1:1	DATE
				PROJECTION:		THIRD ANGLE PROJECTION	CHECKED
				UNIT:	SCALE	REV(NO)	SHEET
						A1	1 OF 1

9 8 7 6 5 4 3 2 1

F
E
D
C
B
A

F
E
D
C
B
A

9 8 7 6 5 4 3 2 1