

REV.	ECN.NO.	APPD.
A0	/	/

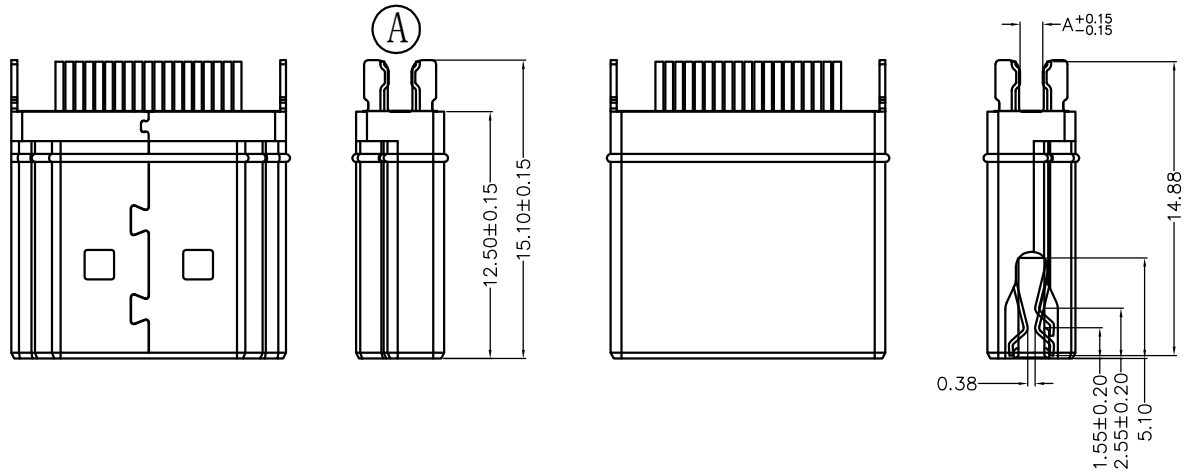
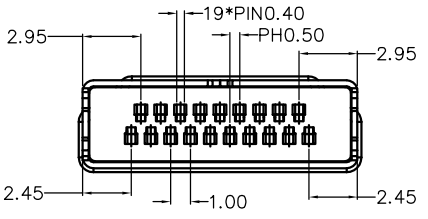

- NOTES:
- MATERIAL:
    - Housing: thermoplastic plastics
    - terminals: Copper Alloy  
Gold plated in contact area:  
Tin plated in termination  
Nickel Plated overall
    - Shell: Steel&Copper Alloy  
Nickel/Au Plated overall
  - ELECTRICAL CHARACTERISTICS:
    - Rating Current :0.5 Ampere
    - Rating Voltage :40 V Max
    - Contact Resistance: 30 Milli ohms
    - Insulation Resistance:100 Mega ohms Min.
  - MECHANICAL CHARACTERISTICS:
    - Connector Mating force: 4.5kg MAX
    - Connector Unmating force:1.0Kg min
    - Durability:10000Cycles.
  - ENVIRONMENT CHARACTERISTICS:
    - Operating temperature:-20℃ to +85℃
    - Storage temperature:-20℃ to +65℃

HD22-3215-G61018

5: 铜壳镀镍  
G: 半金G/Fu

1: 吸塑盒  
1: 黑色  
6: LCP

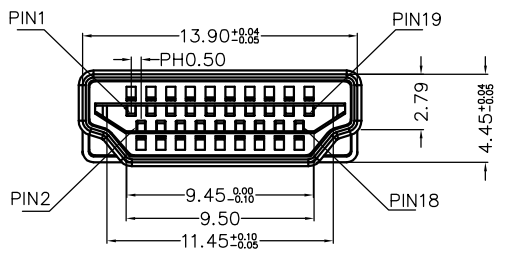
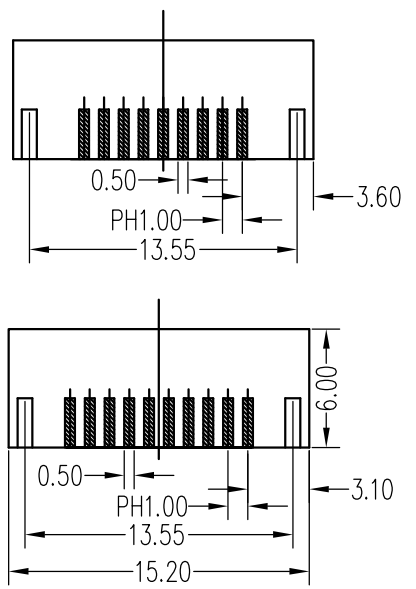

TOLERANCE UNLESS OTHERWISE SPECIFIED	
.XXX ±0.10	.X' ±3'
.XX ±0.20	.XX' ±2'
.X ±0.30	
APPROVED	
CHECKED	
DRAWN	chenyiting
DATE	2023.04.17

<b>HLW</b> 深圳市华联威电子科技有限公司						
HUA LIAN WEI TECHNOLOGY ELECTRONICS CO;LTD.						
PART NAME:		HDMI 19P/M 公头 夹板 1.6				
PART No:		HD22-3215-G61018			C	
DRAWN	chenyiting	PROJECTION:	UNIT:	SCALE:	SHEET:	REV.:
DATE	2023.04.17		mm	1:1	10F1	A0